

CURVED CONVEYOR

GRAVITY FEED 180 DEGREES

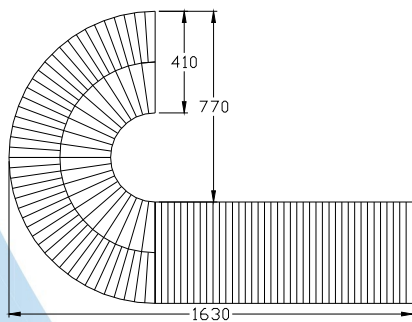

Designed & Manufactured in Australia

Reduce Labor Costs:

Designed to fit behind packaging machinery to return finished product back to the operator who is loading the machine, making a seamless packaging process possible by one operator only.

SPECIFICATIONS:

- Stainless steel side rails
- Height adjustable 750mm – 950mm
- Outside diameter of curve 1180mm
- Inside diameter of curve 360mm
- Length overall 1630mm
- Length straight return section 1050mm
- Rollers 20mm diameter width 410mm
- Close Pitch Differential Rollers with Optional Pitch Spacing
- **CONVM1086SP** Single 52mm pitch suitable for product foot print over 150mm
- **CONVM1086DP** Double 26mm pitch suitable for product foot print from 55mm
- Special size conveyors can be custom built to order.