

# SEMI AUTOMATIC PALLET STRETCH WRAPPER EXP-308

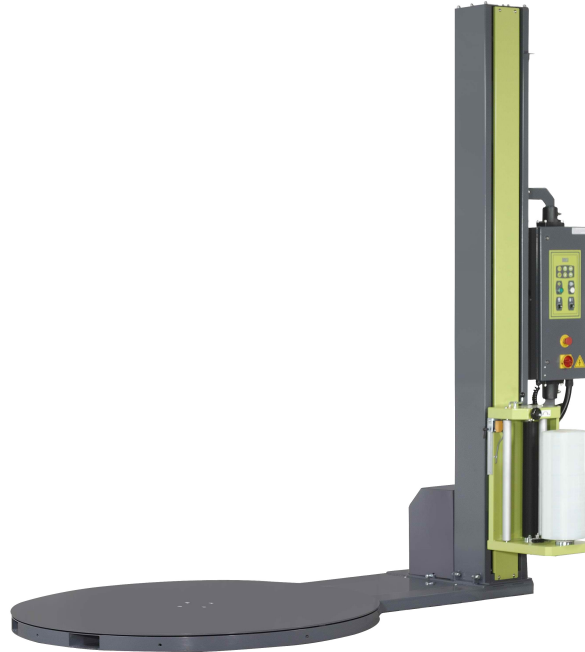

## STANDARD FEATURES:

- Mechanical brake stretch
- Three automatic program cycles
- Trouble shooting shown on screen
- 180 degree rotating control box
- 12 RPM high speed turn table
- Home position: the turntable always stops at the same position
- Turntable jog: can stop the turntable at any desired position
- Both one touch automatic program and manual run are available
- Top/bottom wrapping number programmable
- Height detection by photo electric sensor
- Wrapping tension/turntable speed/carriage speed are adjustable
- Slow start and stop
- Re-set button to make the machine neutral from any operation
- Reinforcing wrapping in the middle of package by manual operation

## OPTIONS

- 1.8m diameter turntable (2000kg) | 1.65m diameter turntable (1650kg)
- 2.5m & 3.0m wrapping height
- 1.5m, 1.65m or 1.8m Ramp
- Horse shoe 1.65m (max load weight 1200kg)

# EXP-308

## SPECIFICATIONS:

<b>Max wrapping height:</b>	2000mm (80")
<b>Max turntable speed:</b>	12 RPM
<b>Max loading weight:</b>	1650kg
<b>Turn table diameter:</b>	1500mm
<b>Power consumption:</b>	0.8Kw
<b>Turn table motor:</b>	½ HP 220V AC, 3 Phase
<b>Carriage motor:</b>	½ HP 220V AC, 3 Phase
<b>Film roll width:</b>	500mm (20")
<b>Film roll outer diameter:</b>	250mm (10")
<b>Film core inner diameter:</b>	76mm (3")
<b>Power Supply:</b>	240V single phase, 10 Amp outlet

